

Oil-sealed Rotary Vacuum Pump **PVD Series**

The PVD series belt-drive oil rotary vane pumps are compact, quiet running and robust.

The superior pumping performance of these industrial strength pumps has earned them an excellent reputation among many users.



PVD-180

Features

- **Consistent Pumping Performance**
The pumping performance of the pump is extremely stable.
- **Low Vibration and Low Noise**
The pump is suitable for use in noise and vibration sensitive environments.
- **Easy Maintenance**
Because the pump body is machined from a single aluminum block casting the unit has fewer parts to maintain.
- **Gas-Ballast Valve**
Gas ballast valve is standard with these pumps to effectively deal with water vapor from condensation.
- **Oil-backflow Prevention**
This model contains an oil-backflow prevention device as standard equipment.
- **Various Options**
An optional base with casters allows ease of movement of the pump.

Applications

- Vacuum drying and freeze drying
- Vacuum packing, vacuum adsorption and transport
- Gas substitution, filling and vacuum heat insulation
- Vacuum casting, etc.

Pumping Speed Curves

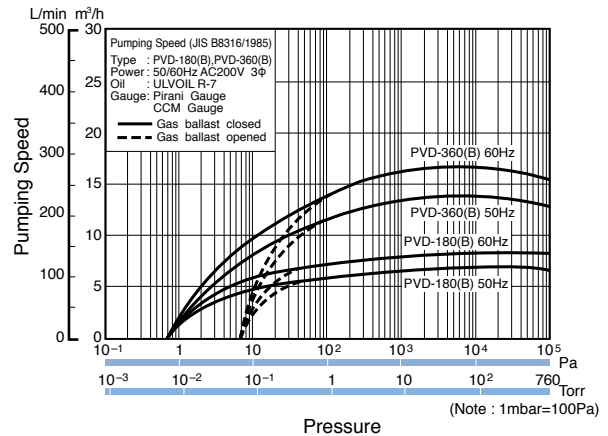

Specifications

Model *1		PVD-180(-B)	PVD-360(-B)
Designed pumping speed	50Hz	m ³ /h	9
		L/min	155
		CFM	5.3
	60Hz	m ³ /h	11
		L/min	186
	CFM	6.47	12.95
Ultimate pressure *2		Pa	0.67
		Torr	5×10 ⁻³
		mbar	6.7×10 ⁻³
Motor *3		Type	Totally Enclosed Fan Cooled Motor
		kw (number of poles)	0.4 (4)
		HP (number of poles)	0.54 (4)
		Rotations	500rpm
	60Hz	600rpm	
Oil *4		ULVOIL R-7	
Oil capacity	L	0.3	0.5
Cooling method		Air cooled	
Inlet (external × internal)		dia. 28 × dia. 19	dia. 34 × dia. 27
Outlet (JIS tube screw)		G3/4 (PF3/4)	G1 (PF1)
Weight	kg	33.5	43
External dimensions W × L × H		mm 235 × 450 × 321	275 × 500 × 321
Options		TMX-1 oil mist trap, adapter for oil mist trap, C-1 or 2 base with handle and casters, BG-1 fully sealed belt cover.	

*1 PVD-B series models (with oil back-flow prevention mechanism) are designated as PVD-180B for the PVD-180 model and PVD-360B for the PVD-360 models.

*2 Measured with a Pirani gauge.

*3 Please specify the need for a motor, the motor model, voltage, and power frequency when ordering.

The fully sealed external fan motor, increased safety explosion-resistant motor, and pressure resistant explosion-resistant motor can also be ordered as options. (Except PVD-B series)

*4 Other oil types are available, upon request.

Dimensions

(unit: mm)

PVD180(B) / 360(B)

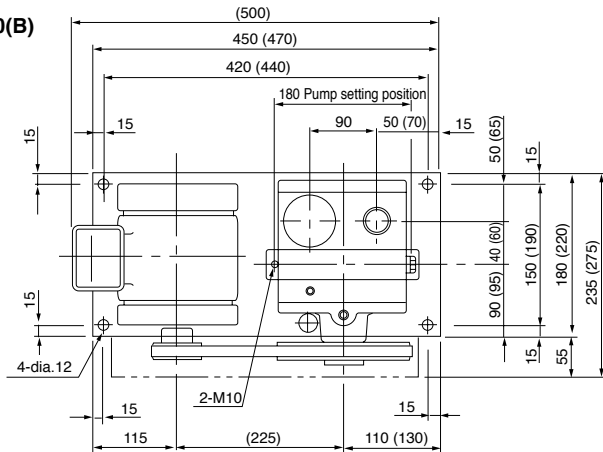

Note) Dimensions in () are for the PVD-360 (B) model. Dimensions not in () are common to all models.

